



List-Magnetik

Manual

MEGA-CHECK FE, FN



LIST-MAGNETIK

Dipl.Ing. Heinrich List GmbH

70771 Leinfelden-Echterdingen · Max-Lang-Str. 56/2
Tel. (0711) – 903631-0 · Fax: (0711) – 903631-10
Internet:<http://www.list-magnetik.de> E-MAIL: info@list-magnetik.de



TABLE OF CONTENTS

MEGA-CHECK FE

V4.1

DESCRIPTION	Page 2
I. SHORT INSTRUCTIONS	Page 2
II. OPERATING INSTRUCTIONS	
A) Charging the hydrid battery	Page 3
B) Calibration	Page 3
C) <i>ONLINE</i> Measurement	Page 4
III. GENERAL REMARKS	Page 4
IV. TECHNICAL DATA	Page 5

LIST-MAGNETIK GmbH

DESCRIPTION

The Coating Thickness Meter MEGA-CHECK FE measures according to the magnetic induction measuring technique (ISO 2178) all non-magnetic coatings, such as varnish, paint, plastics, enamel, rubber, ceramics and galvanic layers (except niquel) on iron and steel.

Measuring range: 0 - 5 mm

MEGA-CHECK FE has a new swinging measuring probe allowing to measure inside pipes and in other inaccessible places.

With the new Statistics Software STAT-6 it is also possible to measure **online** with MEGA-CHECK FE.

I. SHORT INSTRUCTIONS – Calibration

Calibration should **always** be performed with the 300 microns foil, even in the case of thin layers. The 100 microns foil is only supplied to verify the accuracy after calibration.

Key	Display	Function	Device
Press	<input type="text" value="on"/>	Device is switched on	
Press until symbol CAL appears	<input type="text" value="CAL"/>	Calibration	
Release the key	<input type="text" value="CAL"/>	flashing symbol	
Confirm by key stroke	<input type="text" value="0.0"/>	0.0 flashes. Request for zero setting	
	<input type="text" value="0.0"/>		Set the device on the base plate until the indication is steady and beep sounds.
	Example:		<input type="text" value="Take off the device"/>
	<input type="text" value="300"/>	The latest foil value set flashes. Request for calibration with foil.	
	Example:		Set the device on the 298 µm-foil placed on the base plate until the indication is steady and beep sounds.
This value can be changed by key stroke (see value of the foil supplied)	<input type="text" value="298"/>		<input type="text" value="Take off the device"/>

II. OPERATING INSTRUCTIONS

A) Charging the built-in hybrid battery (display → *BAT*)

The hybrid battery is charged with the charger supplied. The cable of the charger is inserted in the socket at the left side of the device and connected to 230 V/50 Hz.

When the battery is empty the charging time should be at least 7 hours.

Battery capacity is sufficient for approx. 8 hours continuous operation.

The advantage of the hybrid battery is that no memory effect appears. Even when the device has been stored for several months it is always ready for operation.

Important

When MEGA-CHECK FE is used for the first time the hybrid battery must be charged.

B) Calibration (→ *CAL* is flashing)

Keep key pressed until the symbol *CAL* flashes. Press the key again to confirm.

1. Zero Setting (→ *0.0* is flashing)

Necessary:

- **When using the device for the first time,**
 - **When measuring on small and curved objects (see General Remarks item 1),**
 - **When measuring on rough surfaces**
- The flashing indication *0.0* requests the operator to place the device on the blank base plate (blue = FE) or on an uncoated test object within 20 sec. As soon as *0.0* is displayed and the beep sounds the device can be taken off.
 - Now the latest foil value entered flashes (see 2.). Foil calibration must be performed within 12 sec. If no foil calibration is necessary, wait until *on* is indicated. MEGA-CHECK FE is ready for operation.

2. Foil Calibration (→ *Foil value* is flashing)

Necessary:

- **When the instrument is used for the first time,**
- **When measuring on small and curved objects (see General Remarks item 1),**
- **When measuring on rough surfaces**

CALIBRATION SHOULD **ALWAYS** BE PERFORMED WITH THE 300 MICRONS FOIL, EVEN IN THE CASE OF THIN LAYERS. THE 100 MICRONS FOIL IS ONLY SUPPLIED TO VERIFY THE ACCURACY AFTER CALIBRATION.

After zero setting:

When the latest calibration value entered flashes, this value can be changed in the range of 90 – 320 μm (see value of your foil). By pressing the key continuously the value scrolls up to >320 μm and begins again at 90 μm . Pressing the key shortly the value diminishes 1 μm .

Release the key, the foil value flashes. Within 12 sec perform the following calibration procedure:

- Place the foil ($\pm 300 \mu\text{m}$) on the base plate and set the device on the foil.
- As soon as the value of the foil is indicated and the beepsounds, the device can be taken off.

MEGA-CHECK FE is now ready for operation.

Remark

The foil value is stored in the device. If you don't need to change the value ignore item 2.

C) ONLINE Measurement

MEGA-CHECK FE is provided with a serial interface, but has no data memory.

Using the graphic statistics software STAT-6 it is possible to measure **online** with MEGA-CHECK FE. The readings are displayed on the screen, stored in the software and evaluated by bar and line diagrams.

III. GENERAL REMARKS

1. Measuring on small or curved objects

When measuring on small or curved objects <10 mm \varnothing both zero setting and foil calibration must be carried out on a geometrically identical uncoated test object.

Also when measuring on base materials with different structures (cast iron, special steels, rough surfaces) calibration should be performed as described above.

2. Thickness of base material > 300 μm

3. Switch over the unit of measurement (μm - mils)

In its basic setting the instrument measures in μm . To switch over to mils the following steps are necessary:

- Switch on the device - Indication on.
- Press the key until the symbol *Un* (unit) flashes. Confirm by another key stroke.
- The unit of measurement is switched over and the device switches off automatically. When switching on again the new unit is indicated.

4. Battery control

As soon as the symbol *BAT* appears on the display there is still time for about 10 min. to continue measuring. After this period the battery must be charged.

If the battery discharge period becomes shorter it should be replaced. In this case please send MEGA-CHECK FE to the manufacturer.

5. Automatic switch-off

The instrument switches itself off automatically one minute after the last measurement. The instrument can also be switched off with key **ON-OFF**.

6. Important

The probe should not be drawn across the testing surface but reset at different spots, i.e. after each measurement hold the instrument in the air for about 1 sec. In doing so the stored calibration is automatically checked and corrected if necessary.

Make sure that the probe surface and the base plate are kept clean and polished at all times.

IV. TECHNICAL DATA

Measuring Technique:	Magnetic induction on iron and steel (ISO 2178)	
Measuring Range:	0 - 5000 μm	
Indication:	LCD 3 ½ digits with floating decimal point and guides for operation	
Resolution:	0 - 100 μm :	0.1 μm
	100 - 1999 μm :	1.0 μm
	> 2000 μm :	0.01 mm
Accuracy:	below 100 μm :	$\pm 1 \mu\text{m}$
	100 - 1000 μm :	$\pm 1 \%$
	1000 - 2000 μm :	$\pm 3 \%$
	> 2000 μm :	$\pm 5 \%$
Power Supply:	Hybrid battery 6.2 V rechargeable	
Battery Capacity:	approx. 8 hours per charge	
Measuring Probe:	swinging by 90°	
Dimensions:	108 x 48 x 38 mm	
Weight:	approx. 100 g	
Warranty:	Indication Unit:	12 months
	Measuring Probe :	3 months

LIST-MAGNETIK GmbH

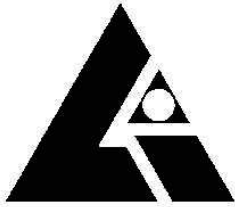

LIST-MAGNETIK

Dipl.Ing. Heinrich List GmbH

70771 Leinfelden-Echterdingen · Max-Lang-Str. 56/2
Tel. (0711) – 903631-0 · Fax: (0711) – 903631-10
Internet:<http://www.list-magnetik.de> E-MAIL: info@list-magnetik.de



TABLE OF CONTENTS

MEGA-CHECK FE-S

Version V4.1

DESCRIPTION	Page	2
I. SHORT INSTRUCTIONS	Page	2
II. OPERATING INSTRUCTIONS		
A) Charging the hybrid battery	Page	4
B) Calibration	Page	4
C) Data Memory	Page	5
1. Display statistics	Page	5
2. Clear individual readings	Page	5
3. Clear the data memory	Page	5
E) Data output to interface		
1. Operation with Printer: DUO-PRINT	Page	5
2. Operation with Computer	Page	5
<i>ONLINE</i> Measurement	Page	5
III. GENERAL REMARKS	Page	6
IV. TECHNICAL DATA	Page	7
V. DATA PRINTER DUO PRINT	Page	7

DESCRIPTION

The Coating Thickness Meter MEGA-CHECK FE-S works according to the magnetic induction measuring technique (ISO 2178) and measures all non-magnetic coatings, such as varnish, paint, plastics, enamel, rubber, ceramics and galvanic layers (except niqel) on iron and steel.

Measuring range: 0 - 5 mm

MEGA-CHECK FE-S has a new swinging measuring probe allowing to measure inside pipes and in other inaccessible places.

The instrument includes a data memory for 100 readings. Statistics can be displayed or transferred together with the readings stored to a printer or PC via the serial interface RS 232 C. The software for evaluation is available on request.

I. SHORT INSTRUCTIONS

a) Functions

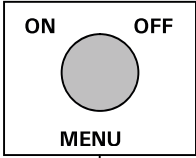
Key	Display	Function
<p>SWITCH ON</p>  <p>Press until the symbol selected appears</p>	<p>Sto</p> <p>↓</p> <p>StA</p> <p>↓</p> <p>Prn</p> <p>↓</p> <p>1CL</p> <p>↓</p> <p>CLr</p> <p>↓</p> <p>CAL</p> <p>↓</p> <p>Un</p> <p>↓</p> <p>on</p>	<p>Store</p> <p>Calibration</p> <p>Print</p> <p>Clear one reading</p> <p>Clear the memory</p> <p>Calibration</p> <p>Unit of measurement µm/mils</p> <p>The device is ready to measure</p>
<p>Flashing symbol is confirmed by key stroke</p>		

b) Calibration

Calibration should ***always*** be performed with the 300 microns foil, even in the case of thin layers. The 100 microns foil is only supplied to verify the accuracy after calibration.

Key	Display	Function	Device
Press	on	Device is switched on	
Press until symbol CAL appears	CAL	Calibration	
Release the key	CAL	flashing symbol	
Confirm by key stroke	0.0	0.0 flashes. Request for zero setting	
	0.0		Set the device on the base plate until the indication is steady and beep sounds.
	Example:		Take off the device
	300	The latest foil value set flashes. Request for calibration with foil.	
	Example:		Set the device on the 298 µm-foil placed on the base plate until the indication is steady and beep sounds.
This value can be changed by key stroke (see value of the foil supplied)	298		Take off the device

Notes

Activate a Menu Function

Press the key until the symbol selected is indicated. Confirm the flashing symbol by key stroke.

If the key is not pressed again within 5 sec or MEGA-CHECK FE-S is set on a test object, the function selected is interrupted and the last reading is indicated or a new measurement can be taken.

II. OPERATING INSTRUCTIONS

A) Charging the built-in hybrid battery (display → *BAT*)

The hybrid battery is charged with the charger supplied. The cable of the charger is inserted in the socket at the left side of the device and connected to 230 V/50 Hz.

When the battery is empty the charging time should be at least 7 hours.

Battery capacity is sufficient for approx. 8 hours continuous operation.

The advantage of the hybrid battery is that no memory effect appears. Even when the device has been stored for several months it is always ready for operation.

Important

When MEGA-CHECK FE-S is used for the first time the hybrid battery must be charged.

B) Calibration (→ *CAL* is flashing)

Keep key pressed until the symbol *CAL* flashes. Press the key again to confirm.

1. Zero Setting (→ *0.0* is flashing)

Necessary:

- **When using the device for the first time,**
- **When measuring on small and curved objects (see General Remarks item 2),**
- **When measuring on rough surfaces**

- The flashing indication *0.0* requests the operator to place the device on the blank base plate (blue = FE) or on an uncoated test object within 20 sec. As soon as *0.0* is displayed and the beep sounds the device can be taken off.
- Now the latest foil value entered flashes (see 2.). Foil calibration must be performed within 12 sec. If no foil calibration is necessary, wait until *on* is indicated. MEGA-CHECK FN is ready for operation.

2. Foil Calibration (→ *Foil value* is flashing)

Necessary:

- **When the instrument is used for the first time,**
- **When measuring on small and curved objects (see General Remarks item 2),**
- **When measuring on rough surfaces**

CALIBRATION SHOULD **ALWAYS** BE PERFORMED WITH THE 300 MICRONS FOIL, EVEN IN THE CASE OF THIN LAYERS. THE 100 MICRONS FOIL IS ONLY SUPPLIED TO VERIFY THE ACCURACY AFTER CALIBRATION.

After zero setting:

When the latest calibration value entered flashes, this value can be changed in the range of 90 – 320 µm (see value of your foil). By pressing the key continuously the value scrolls up to >320 µm and begins again at 90 µm. Pressing the key shortly the value diminishes 1 µm.

Release the key, the foil value flashes. Within 12 sec perform the following calibration procedure:

- Place the foil (± 300 µm) on the base plate and set the device on the foil.
- As soon as the value of the foil is indicated and the beepsounds, the device can be taken off.

MEGA-CHECK FE-S is now ready for operation.

Remark

The foil value is stored in the device. If you don't need to change the value ignore item 2.

C) Data Memory (→ *Sto* is flashing)

MEGA-CHECK FE-S has a data memory to store and evaluate 100 readings.

When the memory has reached its capacity limit the display *FUL* is displayed (memory full).

To switch on/off the data memory press the key until the symbol *Sto* is flashing. Within 5 sec press again the key to enter or leave the memory mode. When switching on the data memory the symbol → *Sto* (Store) appears to make evident that the memory is switched on.

All subsequent measurements will be stored

1. Display Statistics (→ *StA* is flashing)

To display statistics values (No.–MIN–MAX–MEAN–STD.DEV.) proceed as follows:

- Press the key until the symbol *StA* is flashing. Confirm by another key stroke. Now every 2 sec a statistics value is displayed.
- Pressing the key again or setting the probe on a coating the *StA* display mode is deactivated.

2. Clear individual readings (→ *1CL* is flashing)

If a wrong measurement has been stored by mistake, the last reading can be cleared as follows:

- Press the key until the symbol *1CL* is flashing. Confirm by another key stroke.
- The last reading is cleared, and the indication → *1CL* (1 reading cleared) is displayed.

3. Clear the data memory (→ *CLr* is flashing)

- Press the key until the symbol *CLr* flashes. Confirm by another key stroke.
- The data memory is cleared, → *CLr* is displayed.

D) Data output to interface (→ *Prn* is flashing)

1. Operation with Printer DUO-PRINT

The Printer DUO-PRINT must be charged when using it for the first time

When DUO-PRINT is connected the individual readings and statistics MINIMUM, MAXIMUM, MEAN and STANDARD DEVIATION are printed out.

- Connect the printer cable to the instrument socket RS 232 and printer DUO-PRINT.
- Switch on DUO-PRINT and then MEGA-CHECK FE-S.
- Press the key until the symbol *Prn* flashes. Confirm by another key stroke. During the printing procedure → *Prn* is displayed.

2. Operation with Computer

In order to connect MEGA-CHECK FE-S to a Computer an interface cable and either the Data input software **TRANSFER** or the Statistics Software **STAT-6** is required. Both run under WIN 95, 98 or NT.

The Software **TRANSFER** transfers readings to the computer and stores them under an ASCII file.

With the software **STAT-6** the readings are recorded and evaluated by bar and line diagram. With this software you can also measure **online** with the MEGA-CHECK FE-S. Just connect the device to the computer and the graphic representation is updated automatically as soon as a reading is recorded.

Further instructions are supplied with the softwares **TRANSFER** and **STAT-6**.

III. GENERAL REMARKS

1. Socket for interface and battery charger

The socket on the left side of the device serves for connecting the battery charger and simultaneously the interface cable.

2. Measuring on small or curved objects

When measuring on small or curved objects $< 10 \text{ mm } \varnothing$ both zero setting and calibration must be carried out on a geometrically identical uncoated test object.

Also when measuring on base materials with different structures (cast iron, special steels, rough surfaces) calibration should be performed as described above.

3. Thickness of base material > 300 μm

4. Keeping readings and calibration stored

Readings and calibration remain stored after switching off the instrument and even when the battery is empty.

5. Switch over the unit of measurement (μm - mils)

In its basic setting the instrument measures in μm . To switch over to mils the following steps are necessary:

- Switch on the device - Indication on.
- Press the key until the symbol *Un* (unit) flashes. Confirm by another key stroke.
- The unit of measurement is switched over and the device switches off automatically. When switching on again the new unit is indicated.

6. Battery control

As soon as the symbol *BAT* appears on the display there is still time for about 10 min. to continue measuring. After this period the battery must be charged.

If the battery discharge period becomes shorter it should be replaced. In this case please send MEGA-CHECK FE-S to the manufacturer.

7. Automatic switch-off

The instrument switches itself off automatically one minute after the last measurement. The instrument can also be switched off with key **ON-OFF**.

8. Important

The probe should not be drawn across the testing surface but reset at different spots, i.e. after each measurement hold the instrument in the air for about 1 sec. In doing so the stored calibration is automatically checked and corrected if necessary.

Make sure that the probe surface and the base plate are kept clean and polished at all times.

IV. TECHNICAL DATA

Measuring Technique:	Magnetic induction on iron and steel (ISO 2178)
Measuring Range:	0 - 5000 μm
Indication:	LCD 3 ½ digits with floating decimal point and guides for operation
Resolution:	0 - 100 μm : 0.1 μm 100 - 1999 μm : 1.0 μm > 2000 μm : 0.01 mm
Accuracy:	below 100 μm : $\pm 1 \mu\text{m}$ 100 - 1000 μm : $\pm 1 \%$ 1000 - 2000 μm : $\pm 3 \%$ > 2000 μm : $\pm 5 \%$
Memory:	max. 100 readings
Statistics:	Indication of No.-MIN-MAX-MEAN-STD.DEV.
Power Supply:	Hybrid battery 6.2 V rechargeable
Battery Capacity:	approx. 8 hours per charge
Recording Data:	one short beep
Measuring Probe:	swinging by 90°
Dimensions:	108 x 48 x 38 mm
Weight:	approx. 100 g
Interface:	serial RS 232 C (5 V TTL level)
Baudrate:	Printer + PC: 1200 baud
Data bits/Stop bits:	Printer + PC: 7/2
Data Transfer:	by serial Interface RS 232 C to Data Printer DUO-PRINT or with Software STAT-6 or TRANSFER to Computer
Warranty:	Indication Unit: 12 months Measuring Probe : 3 months

V. DATA PRINTER DUO-PRINT

Technical Data:

Type of Printer:	Needle printer
Characters/Line:	16
Data Transfer Rate:	1200 baud
Printing Velocity:	approx. 1 line/sec.
Interface:	serial
Print Ribbon:	Cassette type MP 190 (blue)
Paper:	Standard wood-free paper roll 45 mm wide max. roll diameter 50 mm
Power Supply:	NiCad Accumulator (approx. 5000 printed lines/charge)
Dimensions:	160 x 80 x 35 mm
Weight:	approx. 390 g
Charging Unit:	220 V/50 Hz - 7,5 V

Charging the built-in NiCad Accumulator

Before using DUO-PRINT for the first time the built-in NiCad accumulator must be charged.

The built-in NiCad accumulator is charged with the charging unit supplied with the printer. The cable of the charging unit is connected at the right-hand socket of DUO-PRINT.

The charging time should not exceed 7 hours.

Operating Instructions

1. The operation of DUO-PRINT together with the Coating Thickness Meter MEGA-CHECK FE-S is explained in the operating instructions of MEGA-CHECK FE-S (Page 8 - F).
2. When the printer DUO-PRINT is connected to the Coating Thickness Meter MEGA-CHECK FE-S, DUO-PRINT switches on and off automatically (switch position 'ON'). During the printout the red LED control lamp lights up. When printout is finished DUO-PRINT switches off automatically, i.e. the red control lamp goes off (consumption of closed circuit current < 80 µA).

If DUO-PRINT is to be switched off for a longer period of time or if it is not connected by a connecting cable, DUO-PRINT must be switched off with the **ON-OFF** switch.
3. The manual paper feed is effected with key **PAPER FEED**. When the printout is finished the paper stripe is transported out of the casing by pressing this key and can be neatly turned off.

4. Faulty print out

Incorrect printed lines mean that the printer should be recharged.

Changing Ribbon Cassette

1. When changing ribbon cassette there must not be a paper roll in the printing unit. If necessary cut off the paper roll and feed the rest of paper out of the printing unit by pressing key **PAPER FEED**.
2. Press the upper lid of the casing and remove it. The ribbon is located in a cassette and can easily be exchanged.
3. **Taking out Ribbon Cassette:**
Press down the cassette on the right hand side where it says **PUSH**. Then the ribbon cassette can be removed.
4. **Inserting Ribbon Cassette:**
Make the ribbon taut by turning the rotating knob on the left hand side of the cassette. Then slip the cassette into position taking care that the ribbon goes into the slid. Replace the lid of the casing.

Inserting new paper roll

Place the paper roll on the paper cradle and insert the end of the roll in the slid at the rear of the printer. Press key **PAPER FEED**. The paper is fed into the printing mechanism automatically.

OPERATION MANUAL

COATING THICKNESS METER

MEGA-CHECK FN

2015-09



LIST-MAGNETIK
Dipl.-Ing. Heinrich List GmbH
Max-Lang-Str. 56/2
D-70771 Leinfelden-Echterdingen
Tel: +49 (711) 903631-0
Fax: +49 (711) 903631-10
E-mail: info@list-magnetik.de
Internet: <http://www.list-magnetik.de>



TABLE OF CONTENTS

MEGA-CHECK FN (2015-09)

DESCRIPTION	2
SHORT INSTRUCTIONS	3
Functions	3
Display	3
Function	3
SWITCH ON	3
Calibration.....	4
Notes	5
Activate a Menu Function	5
Switching over the measuring mode (AUt ↔ NFE)	5
OPERATING INSTRUCTIONS	6
Charging the built-in hydrid battery (display → <i>BAT</i>)	6
Calibration (→ <i>CAL</i> is flashing)	7
Remark.....	7
GENERAL REMARKS	9
TECHNICAL DATA	10
Data Printer DUO-PRINT	11

DESCRIPTION

The Coating Thickness Meter MEGA-CHECK FN works according to both measuring principles, magnetic induction (ISO 2178) and eddy current (ISO 2360).

When placing the probe the instrument recognizes by itself on which base material (FE or NFE) measurement is performed.

It can be used for measuring:

Magnetic Induction (FE)

On base material iron and steel all non-magnetic coatings, such as varnish, paint, plastics, enamel, rubber, ceramics and galvanic layers except nickel.

Measuring range: 0 - 5 mm

Eddy Current (NFE)

On non-ferrous metals (aluminium, brass, bronze, zinc, lead, copper and non-magnetic steels) all non-conductive coatings, such as varnish, paint, plastics, rubber and anodizing. Insulating coatings on zinc plated steel (see page 5).

Measuring range: 0 – 2 mm

MEGA-CHECK FN has a new swivelling measuring probe allowing to measure inside pipes and in other inaccessible places.

The instrument includes a data memory for 100 readings. Statistics can be displayed or transferred together with the readings stored to a printer or PC via the serial interface RS 232 C. The software for evaluation is available on request.

SHORT INSTRUCTIONS

FUNCTIONS

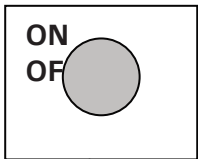
Key	Display	Function
<p>SWITCH ON</p>  <p>Press until the symbol selected appears</p> <p>Flashing symbol is confirmed by key stroke</p>	<pre> graph TD A[Sto] --> B[StA] B --> C[Prn] C --> D[1CL] D --> E[CLr] E --> F[CAL] F --> G["NFE/ AC"] G --> H[Un] H --> I[on] </pre>	<p>Store</p> <p>Display statistics</p> <p>Print</p> <p>Clear one reading</p> <p>Clear the memory</p> <p>Calibration</p> <p>NFE Eddy current AUt Automatic mode</p> <p>Unit of measurement µm/mils</p> <p>The device is ready to measure</p>

CALIBRATION

Calibration should always be performed with the 300 microns foil, even in the case of thin layers. The 100 microns foil is only supplied to verify the accuracy after calibration.

Key	Display	Function	Device
Press	<input type="text" value="on"/>	Device is switched on	
Press until symbol CAL appears	<input type="text" value="CAL"/>	Calibration	
Release the key	<input type="text" value="CAL"/>	flashing symbol	
Confirm by key stroke	<input type="text" value="0.0"/>	0.0 flashes. Request for zero setting	
	<input type="text" value="0.0"/>		Set the device on the base plate until the indication is steady and beep sounds.
	Example:		<input type="text" value="Take off the device"/>
	<input type="text" value="300"/>	The latest foil value set flashes. Request for calibration with foil.	
	Example:		Set the device on the 298 μm-foil placed on the base plate until the indication is steady and beep sounds.
This value can be changed by key stroke (see value of the foil supplied)	<input type="text" value="298"/>		<input type="text" value="Take off the device"/>

NOTES

ACTIVATE A MENU FUNCTION

Press the key until the symbol selected is indicated. Confirm the flashing symbol by key stroke.

If the key is not pressed again within 5 sec or MEGA-CHECK FN is set on a test object, the function selected is interrupted and the last reading is indicated or a new measurement can be taken.

SWITCHING OVER THE MEASURING MODE (AUT ↔ NFE)

a) *AUt* – Automatic Measuring Mode

When the probe is set on the base material (FE or NFE) the measuring mode is switched over automatically. The correct base material (*FE* or *NFE*) blinks shortly before the measuring value is indicated.

Eddy current:

Non-conductive coatings on non-ferrous metals: indication →*NFE*.
Measurement is recorded by one short beep.

Magnetic induction:

Insulating and galvanic coatings (except nickel) on ferrous metals: indication →*FE*.
Measurement is recorded by one short beep.

b) *NFE* – Measurement on zinc plated steel

MEGA-CHECK FN has an additional feature making it possible to measure with the eddy current technique layers on zinc plated steel provided the thickness of the zinc plating is higher than 20 microns.

For this special measuring problem the automatic measuring mode must be deactivated and the eddy current mode (*NFE*) is set manually.

Press the key until the symbol *NFE* appears. Press again within 5 sec to activate the eddy current mode.

Important

When measuring galvanic or insulating layers on ferrous base material switch back to the automatic mode (indication *AUt*) to avoid wrong readings with the eddy current mode!

OPERATING INSTRUCTIONS

CHARGING THE BUILT-IN HYBRID BATTERY (DISPLAY →*BAT*)

The hybrid battery is charged with the charger supplied. The cable of the charger is inserted in the socket at the left side of the device and connected to 230 V/50 Hz.

When the battery is empty the charging time should be at least 7 hours.

Battery capacity is sufficient for approx. 8 hours continuous operation.

The advantage of the hybrid battery is that no memory effect appears. Even when the device has been stored for several months it is always ready for operation.

Important

When MEGA-CHECK FN is used for the first time the hybrid battery must be charged.

CALIBRATION (→ *CAL* IS FLASHING)

Keep key pressed until the symbol *CAL* flashes. Press the key again to confirm.

1. Zero Setting (→ *0.0* is flashing)

Necessary:

- **When using the device for the first time,**
- When measuring on small and curved objects using the eddy current technique (NFE) (see General Remarks item 2),
- **When measuring on rough surfaces**
 - The flashing indication *0.0* requests the operator to place the device on the blank base plate (blue = FE or red = NFE) or on an uncoated test object within 20 sec. As soon as *0.0* is displayed and the beep sounds the device can be taken off.
 - Now the latest foil value entered flashes (see 2.). Foil calibration must be performed within 12 sec. If no foil calibration is necessary, wait until *on* is indicated. MEGA-CHECK FN is ready for operation.

2. Foil Calibration (→ *Foil value* is flashing)

Necessary:

- **When the instrument is used for the first time,**
- **When measuring on small and curved objects with the eddy current technique (NFE)** (see General Remarks item 2),
- **When measuring on rough surfaces**

CALIBRATION SHOULD **ALWAYS** BE PERFORMED WITH THE 300 MICRONS FOIL, EVEN IN THE CASE OF THIN LAYERS. THE 100 MICRONS FOIL IS ONLY SUPPLIED TO VERIFY THE ACCURACY AFTER CALIBRATION.

After zero setting:

When the latest calibration value entered flashes, this value can be changed in the range of 90 – 320 μm (see value of your foil). By pressing the key continuously the value scrolls up to >320 μm and begins again at 90 μm . Pressing the key shortly the value diminishes 1 μm .

Release the key, the foil value flashes. Within 12 sec perform the following calibration procedure:

- Place the foil ($\pm 300 \mu\text{m}$) on the base plate and set the device on the foil.
- As soon as the value of the foil is indicated and the beepsounds, the device can be taken off.

MEGA-CHECK FN is now ready for operation.

Remark

The foil value is stored in the device. If you don't need to change the value ignore item 2.

C) Data Memory (→ *Sto* is flashing)

MEGA-CHECK FN has a data memory to store and evaluate 100 readings.

When the memory has reached its capacity limit the display *FUL* is displayed (memory full).

To switch on/off the data memory press the key until the symbol *Sto* is flashing. Within 5 sec press again the key to enter or leave the memory mode. When switching on the data memory the symbol → *Sto* (Store) appears to make evident that the memory is switched on.

All subsequent measurements will be stored.

1. **Display Statistics** (→ *StA* is flashing)

To display statistics values (No.–MIN–MAX–MEAN–STD.DEV.) proceed as follows:

- Press the key until the symbol *StA* is flashing. Confirm by another key stroke. Now every 2 sec a statistics value is displayed.
- Pressing the key again or setting the probe on a coating the *StA* display mode is deactivated.

2. **Clear individual readings** (→ *1CL* is flashing)

If a wrong measurement has been stored by mistake, the last reading can be cleared as follows:

- Press the key until the symbol *1CL* is flashing. Confirm by another key stroke.
- The last reading is cleared, and the indication → *1CL* (1 reading cleared) is displayed.

3. **Clear the data memory** (→ *CLr* is flashing)

- Press the key until the symbol *CLr* flashes. Confirm by another key stroke.
- The data memory is cleared, → *CLr* is displayed.

D) **Data output to interface** (→ *Prn* is flashing)

1. **Operation with Printer DUO-PRINT**

The Printer DUO-PRINT must be charged when using it for the first time.

When DUO-PRINT is connected the individual readings and statistics MINIMUM, MAXIMUM, MEAN and STANDARD DEVIATION are printed out.

- Connect the printer cable to the instrument socket RS 232 and printer DUO-PRINT.
- Switch on DUO-PRINT and then MEGA-CHECK FN.
- Press the key until the symbol *Prn* flashes. Confirm by another key stroke. During the printing procedure → *Prn* is displayed.

2. **Operation with Computer**

In order to connect MEGA-CHECK FN to a Computer an interface cable and either the Data input software **TRANSFER** or the Statistics Software **STAT-6** is required. Both run under WIN 95, 98 or NT.

The Software **TRANSFER** transfers readings to the computer and stores them under an ASCII file.

With the software **STAT-6** the readings are recorded and evaluated by bar and line diagram.

With this software you can also measure **online** with the MEGA-CHECK FN. Just connect the device to the computer and the graphic representation is updated automatically as soon as a reading is recorded.

Further instructions are supplied with the softwares **TRANSFER** and **STAT-6**.

E) **Error Indication**

• **When measuring on steel (FE) a wrong reading and →NFE is indicated**

Reason: Measurement has been carried out with the eddy current principle on ferrous base material.

Help: Switch-over to automatic mode (→ *AUt*)

• **When measuring on steel (FE) or non-ferrous metals (NFE) the indication - - - appears**

Reason: The measuring range is exceeded.

GENERAL REMARKS

1. Socket for interface and battery charger

The socket on the left side of the device serves for connecting the battery charger and simultaneously the interface cable.

2. Measuring on small or curved objects

When measuring on small or curved objects <10 mm \varnothing both zero setting and calibration must be carried out on a geometrically identical uncoated test object.

Also when measuring on base materials with different structures (cast iron, special steels, rough surfaces) calibration should be performed as described above. That goes for both measuring techniques (*FE and NFE*).

3. Thickness of base material

Ferrous base material (FE): > 300 μm

Non-ferrous base material (NFE): > 50 μm

4. Keeping readings and calibration stored

Readings and calibration remain stored after switching off the instrument and even when the battery is empty.

5. Switch over the unit of measurement (μm - mils)

In its basic setting the instrument measures in μm . To switch over to mils the following steps are necessary:

- Switch on the device - Indication *on*.
- Press the key until the symbol *Un* (unit) flashes. Confirm by another key stroke.
- The unit of measurement is switched over and the device switches off automatically. When switching on again the new unit is indicated.

6. Battery control

As soon as the symbol *BAT* appears on the display there is still time for about 10 min. to continue measuring. After this period the battery must be charged.

If the battery discharge period becomes shorter it should be replaced. In this case please send MEGA-CHECK FN to the manufacturer.

7. Automatic switch-off

The instrument switches itself off automatically one minute after the last measurement. The instrument can also be switched off with key **ON-OFF**.

8. Important

The probe should not be drawn across the testing surface but reset at different spots, i.e. after each measurement hold the instrument in the air for about 1 sec. In doing so the stored calibration is automatically checked and corrected if necessary.

Make sure that the probe surface and the base plate are kept clean and polished at all times.

TECHNICAL DATA

Measuring Techniques:	Magnetic induction on iron and steel (ISO 2178) Eddy current on non-ferrous metals and non-magnetic steels (ISO 2360)
Switch over Measuring Technique:	Automatic or manual (NFE)
Measuring Ranges:	Magnetic Induction: 0 - 5000 μm (FE) Eddy Current: 0 - 2000 μm (NFE)
Indication:	LCD 3 1/2 digits with floating decimal point and guides for operation
Resolution:	0 - 100 μm : 0.1 μm 100 - 1999 μm : 1.0 μm > 2000 μm : 0.01 mm
Accuracy:	below 100 μm : $\pm 1 \mu\text{m}$ 100 - 1000 μm : $\pm 1 \%$ 1000 - 2000 μm : $\pm 3 \%$ > 2000 μm : $\pm 5 \%$
Memory:	max. 100 readings
Statistics:	Indication of No.-MIN-MAX-MEAN-STD.DEV.
Power Supply:	Hybrid battery 6.2 V rechargeable
Battery Capacity:	approx. 8 hours per charge
Recording Data:	on steel (FE) and on non-ferrous metals (NFE): one short beep
Measuring Probe:	swivelling by 90°
Dimensions:	108 x 48 x 38 mm
Weight:	approx. 100 g
Interface:	serial RS 232 C (5 V TTL level)
Baudrate:	Printer + PC: 1200 baud
Data bits/Stop bits:	Printer + PC: 7/2
Data Transfer:	by serial Interface RS 232 C to Data Printer DUO-PRINT or with Software STAT-6 or TRANSFER to Computer
Warranty:	Indication Unit: 12 months Measuring Probe : 3 months

DATA PRINTER DUO-PRINT

Technical Data:

Type of Printer:	Needle printer
Characters/Line:	16
Data Transfer Rate:	1200 baud
Printing Velocity:	approx. 1 line/sec.
Interface:	serial
Print Ribbon:	Cassette type MP 190 (blue)
Paper:	Standard wood-free paper roll 45 mm wide max. roll diameter 50 mm
Power Supply:	NiCad Accumulator (approx. 5000 printed lines/charge)
Dimensions:	160 x 80 x 35 mm
Weight:	approx. 390 g
Charging Unit:	220 V/50 Hz - 7,5 V

Charging the built-in NiCad Accumulator

Before using DUO-PRINT for the first time the built-in NiCad accumulator must be charged.

The built-in NiCad accumulator is charged with the charging unit supplied with the printer. The cable of the charging unit is connected at the right-hand socket of DUO-PRINT.

The charging time should not exceed 7 hours.

Operating Instructions

1. The operation of DUO-PRINT together with the Coating Thickness Meter MEGA-CHECK FN is explained in the operating instructions of MEGA-CHECK FN (Page 8 - F).
2. When the printer DUO-PRINT is connected to the Coating Thickness Meter MEGA-CHECK FN, DUO-PRINT switches on and off automatically (switch position 'ON'). During the printout the red LED control lamp lights up. When printout is finished DUO-PRINT switches off automatically, i.e. the red control lamp goes off (consumption of closed circuit current < 80 μ A).

If DUO-PRINT is to be switched off for a longer period of time or if it is not connected by a connecting cable, DUO-PRINT must be switched off with the **ON-OFF** switch.

3. The manual paper feed is effected with key **PAPER FEED**. When the printout is finished the paper stripe is transported out of the casing by pressing this key and can be neatly turned off.

4. **Faulty print out**

Incorrect printed lines mean that the printer should be recharged.

Changing Ribbon Cassette

1. When changing ribbon cassette there must not be a paper roll in the printing unit. If necessary cut off the paper roll and feed the rest of paper out of the printing unit by pressing key **PAPER FEED**.
2. Press the upper lid of the casing and remove it. The ribbon is located in a cassette and can easily be exchanged.
3. **Taking out Ribbon Cassette:**
Press down the cassette on the right hand side where it says **PUSH**. Then the ribbon cassette can be removed.

4. **Inserting Ribbon Cassette:**

Make the ribbon taut by turning the rotating knob on the left hand side of the cassette. Then slip the cassette into position taking care that the ribbon goes into the slid. Replace the lid of the casing.

Inserting new paper roll

Place the paper roll on the paper cradle and insert the end of the roll in the slid at the rear of the printer. Press key **PAPER FEED**. The paper is fed into the printing mechanism automatically.

**INTERNET INQUIRY
CUSTOMER'S SATISFACTION**

We would like to point out to the form in our homepage www.list-magnetik.de. We would be grateful if you take a little time and fill it out. You can help us to reach our quality target regarding ISO 9001-2000.

THANK YOU !

We supply:

- Coating Thickness Meters
- Surface Testing Devices
- Ultrasonic Thickness Gauges
- Magnetic Measuring Instruments
- Magnetizing and Demagnetizing Equipment

We advise and take care of all your problems

Fast Service



LIST-MAGNETIK
Dipl.-Ing. Heinrich List GmbH
Max-Lang-Str. 56/2
D-70771 Leinfelden-Echterdingen
Tel: +49 (711) 903631-0
Fax +49 (711) 90363110
E-mail: info@list-magnetik.de
Internet: <http://www.list-magnetik.de>

