

List-Magnetik

Manual

MP-810A, 810T

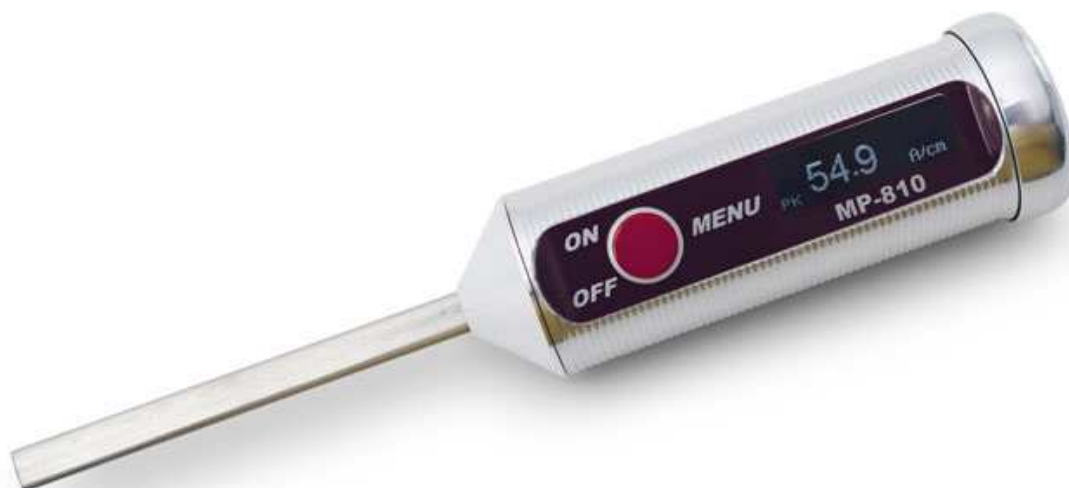

OPERATION MANUAL

MAGNETIC FIELD METER MP-810A / MP-810T

Revision number 1.000.0 and up

2024-02



List-Magnetik Dipl.-Ing. Heinrich List GmbH
D-70771 Leinfelden-Echterdingen Max-Lang-Str. 56/2
Fon: + 49 (711) 903631-0 Fax: + 49 (711) 903631-10
Internet: <https://www.list-magnetik.com>
E-mail: info@list-magnetik.de



CONTENT

1	Introduction	2
2	Short user guide	2
2.1	Ranges and types of magnetic fields	2
2.2	Warnings and hazard information	3
3	Axial / transversal measurement probes	4
3.1	Checking with calibration standard	4
3.1.1	MP-810A with Axial field probe	4
3.1.2	MP-810T with Transversal field probe	4
4	Measurement display	5
5	Operating the device with the red button	5
6	Menu functions	6
6.1	Switch off	6
6.2	Calibration	6
6.3	Probe mode (DC/AC/Peak)	7
6.3.1	DC	7
6.3.2	AC	8
6.3.3	Peak value measurement	8
6.4	Memory	9
6.4.1	Delete last value	9
6.4.2	Disable Memory	10
6.4.3	Memory batch M1 / M2 / M3 etc.	10
6.4.4	New memory batch	14
6.4.5	Delete all batches	14
6.5	Settings	15
6.5.1	Language	15
6.5.2	Unit	15
6.5.3	Switch-off time	16
6.5.4	Beep Volume	17
6.5.5	Contrast	17
6.6	System	18
7	Battery replacement	19
7.1	Using a rechargeable battery	19
8	Technical Data	20
9	Available applications	21
9.1.1	Lima Connect for Windows	21
9.1.2	Lima Connect App for Android and iOS	22

1 INTRODUCTION

The smallest and most attractive magnetic field meter: The latest addition to our line of precision magnetic field meters. The **List-Magnetik MP-810** is easy to use and comfortable to use. Accurately measures all types of magnetic fields: AC fields, DC fields and peak values in pulse fields.

The measuring ranges and the different units A/cm, Gauss/Oersted, (Milli-)Tesla meet all requirements.

The MP-810 is available with either a fixed axial probe (MP-810A) or a fixed transversal probe (MP-810T). The axial field probe measures the field in the direction of the probe axis at a precise distance of 2.0 mm. It is suitable for measurements on flat surfaces or especially in drilled holes.

The transversal field probe measures in 90° angle to the probe axis particularly in air gaps, cavities and on the surface of workpieces, suitable for crack detection.

We have taken great care to ensure that these operating instructions are as clear and concise as possible.

However, if you still have questions about the operation, please contact our service technicians who are always available. They will be happy to assist you.

2 SHORT USER GUIDE

You can start measuring magnetic fields right away without any manual adjustments. Simply turn on the instrument with the red button. After power on, the instrument will automatically zero itself. The sensor must not be in a magnetic field during this process.

That's it! You can now make your first measurement in the constant field (DC field) range.

2.1 RANGES AND TYPES OF MAGNETIC FIELDS

The **MP-810** field measurement device can be used to measure practically any type of magnetic fields - constant fields (DC) and alternating fields (AC), in the range from 0.1 to 20,000 A/cm.

In the other measurement units, this range represents:

0.01 to 2,000 **kA/m**

0.1 to 20,000 **Gauss** (Oersted)

0.01 to 2,000 **mT** = 2.0 T

2.2 WARNINGS AND HAZARD INFORMATION

List-Magnetik expressly points out that the MP-810 magnetic field meter must be used may only be used for its intended purpose, the measurement of magnetic fields. Any other use is inadmissible and involves incalculable risks for the instrument and the operator. and the operator.



The operator of the equipment must ensure that it is used only by personnel who have access to, and have read and understood, this operating manual.



Under no circumstances should the instrument and sensor be brought into contact with sources of electrical power that are not adequately insulated. Failure to observe this warning may result in death to the operator.



Although the unit is splash-proof, it is not waterproof. Do not immerse the device in water or other liquids or clean it with water. If the device comes into contact with a liquid medium, it must be switched off immediately.



Do not use the instrument in an explosive environment (fumes, gases). The use of any electrical device, including this battery-powered meter, may cause an explosion.



Do not open the unit except to replace the battery. Do not attempt to repair the electrical system yourself. Instead, return the unit to us for diagnosis in the event of a malfunction.

3 AXIAL / TRANSVERSAL MEASUREMENT PROBES

Axial probe MP-810A

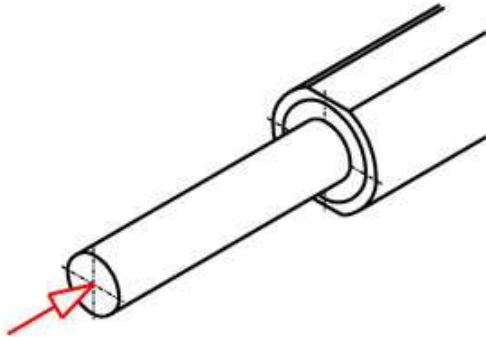

Transversal probe MP-810T

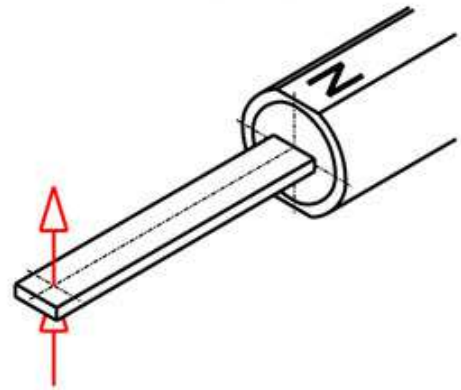

The axial field sensor measures the field along the longitudinal axis of the device at a precise distance of 2 mm and is suitable for measuring on planar or curved surfaces and particularly in bores.

The transversal field sensor, on the other hand, measures perpendicular to the sensor axis (90°) and is suitable for measuring in air gaps, hollow spaces or on the surface of workpieces (e.g. for crack testing).

3.1 CHECKING WITH CALIBRATION STANDARD

It is not necessary to calibrate the device - it is pre-calibrated at the factory.

A calibration standard with **180 A/cm** is available as an option, in order to be able to check the device. .

If a deviation is detected when checking with the calibration standard, we advise returning the device for recalibration at the factory.

3.1.1 MP-810A WITH AXIAL FIELD PROBE

Place the probe inside the ring on top of the calibration standard and position or rotate the instrument until the maximum value is displayed. Then compare the displayed value to the value of the calibration standard.

3.1.2 MP-810T WITH TRANSVERSAL FIELD PROBE

Place the probe in the center of the ring on the top of the calibration standard with the N (North Pole) mark facing up. Position the probe until the maximum value is displayed. Then compare the displayed value to the value of the calibration standard.

4 MEASUREMENT DISPLAY

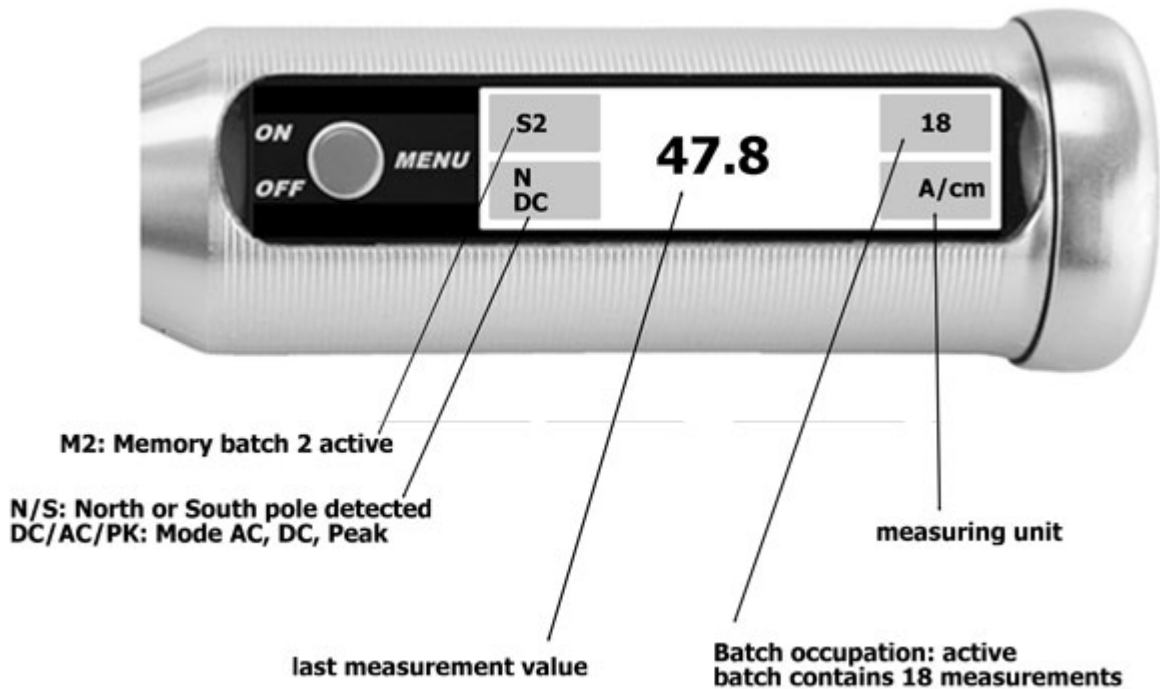

The measurement display shows the most recent measurement and its unit at a glance. At the bottom left, the type of measurement (DC/AC/PK=Peak) and the polarity (N=North/S=South) are displayed.

In addition, the used memory and its current allocation with measured values are displayed.

5 OPERATING THE DEVICE WITH THE RED BUTTON

Press the key briefly to scroll through the menu functions, press and hold the key (with signal tone) to activate the desired menu function.

At the end of each submenu there is a display < **back** that allows you to exit the submenu and return to the next higher level.

After 10 seconds of inactivity without pressing any key, the device always returns to the measurement display.

In the delivery state, English is preselected as the language.

6 MENU FUNCTIONS

6.1 SWITCH OFF

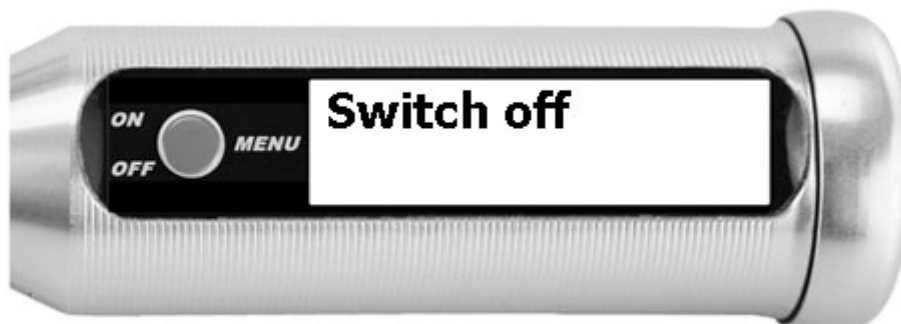

By pressing the key for a long time (long signal tone), the device is switched off manually.

The automatic turnoff time is 30 minutes in the delivery state and can be changed under the menu item **Setup / Switch Off Time**.

6.2 CALIBRATION



To adjust the zero point, press and hold the red button.

The probe must not be in a magnetic field. After zeroing, a reading of ± 0.2 will usually appear due to the influence of the earth's magnetic field when the probe is moved.

6.3 PROBE MODE (DC/AC/PEAK)



With the MP-810 you can measure direct and alternating fields.

With the peak function it is possible to determine the maximum value of a field. If there is already a reading in the peak value memory and a higher reading is registered, the old reading will be overwritten by the new reading. A short beep sounds when the reading is overwritten.

When alternating fields are measured in peak value memory mode, the peak value (and not the RMS value) is displayed for sinusoidal alternating fields.

The currently selected measurement type (DC, AC, Peak) is displayed in the lower left corner next to the measurement value.

The active probe mode is indicated by an asterisk (*) behind the entry.

6.3.1 DC



Enable direct field (DC) measurement.

For DC fields, the north polarity is indicated by an **N** and the south polarity is indicated by an **S** to the left of the reading.

6.3.2 AC



Activate the AC measurement.

For sinusoidal AC fields, the true RMS value is displayed. The conversion factors for full-wave and half-wave rectification are specified in DIN standard 54 131 Part 1.

6.3.3 PEAK VALUE MEASUREMENT



Enable Peak Value Measurement (PK).

The measured value is only updated if it is higher than the previous maximum value. The polarity is irrelevant.

To reset the peak value, select **Reset Peak**, a menu item that only appears in Peak mode.

6.4 MEMORY

The storage of the measured values is switched on when either a new memory batch is created or an existing one is activated.

A maximum of 9 memory batches are possible, which can be filled almost arbitrarily (approx. 4000 measured values). If the total possible memory space is exceeded, a warning message is issued that no more values can be stored.

To indicate that the memory is switched on, the symbol **M** appears at the top left of the measurement display followed by the number of the active memory batch, for example **M2** for memory batch number 2.

Switching the device off and on does not change the setting, the status of whether and which memory batch is active, is retained.

With the **Disable Mem** function, you can switch off the storage again.

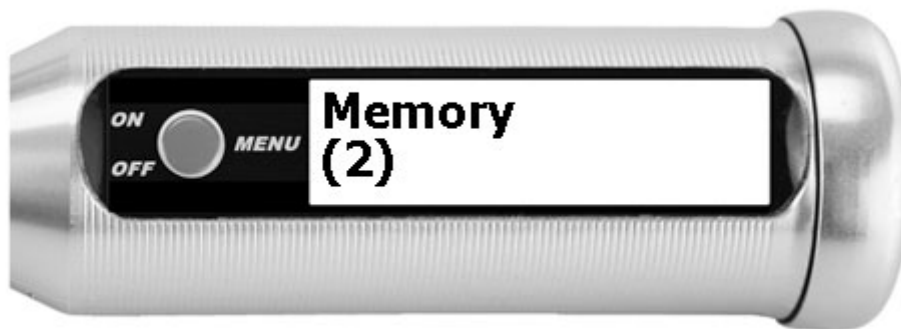

Under the word **Memory** the number of currently available memory batches is displayed - here: 2 memory batches are created.

6.4.1 DELETE LAST VALUE



Deleting the last stored measurement value:

Example: You have performed an incorrect measurement and want to remove it from your measurement series immediately. The function can be repeated and then deletes the second to last value, the third to last value and so on.

Deletion is only possible for values of the current memory batch (here: batch 2).

6.4.2 DISABLE MEMORY



With the **Disable memory** function, you can explicitly switch off the storing of measurement values.

The memory function is then automatically switched on again when either a new memory is created or an existing one is activated.

6.4.3 MEMORY BATCH M1 / M2 / M3 ETC.



The created memory batches are listed one after the other in the menu.

The number of the batch (here: batch number 2) and the number of the values contained in it (here: 15) are displayed in the bottom line in a slightly smaller size.

To view and manage the memory batch in detail, press the red button long.

To jump to the next memory batch, press the red button briefly.

6.4.3.1 Activate



With activation, all measurements are written to this memory batch from now on. All other batches remain unchanged.

This memory batch is active until the storage is generally terminated (disable memory), another batch is activated, or the batch is deleted.

6.4.3.2 Statistics

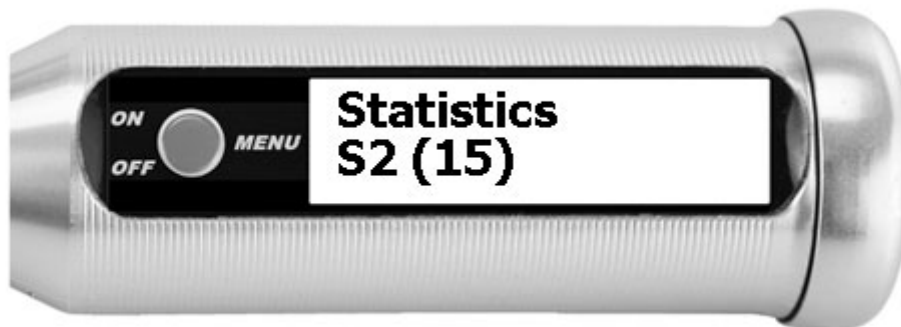

The display of the statistics shows successively by keystroke these values in the selected batch:

Count	– number of stored measurement values *
Minimum	– smallest stored measurement value
Maximum	– biggest stored measurement value
Mean	– average value
Std.Dev	– standard deviation (corrected sample variance)

* A displayed **Count 15 (13)** means that there are two crossed-out but not yet optimized (and so finally deleted) values in the batch. Only the 13 values that are active are taken into account in the statistics (see chapter: Optimize).

6.4.3.3 Browse



In the browse function, all measurement values of the batch are displayed. Always 2 values are displayed and by pressing the key it is scrolled by one value. The upper line is marked with a triangle on the left.

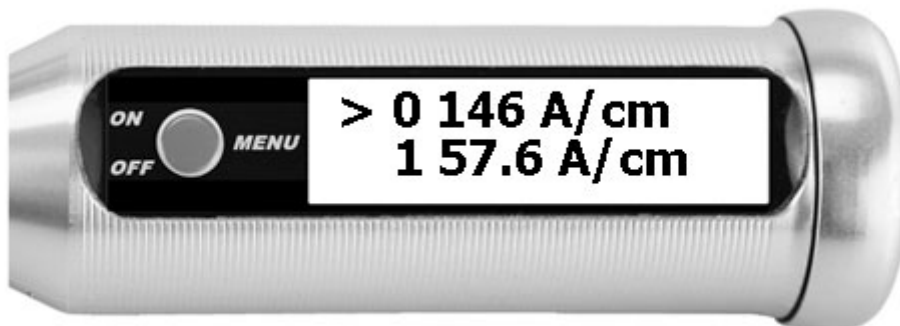

This measurement value marked with the triangle can be deleted by a long keystroke. It is then displayed crossed out. A crossed-out / inactive value is no longer included in the statistics and is no longer transferred to the PC or mobile app.



A deleted value can be reactivated by pressing and holding the key again. The crossed-out value is only finally deleted by **Optimize**.

To exit the function, please wait until the display returns to the menu after a few seconds.

6.4.3.4 Optimize



The memory batch is cleaned up. Deleted measurement values are removed and are no longer visible when scrolling. The numbering of the measurement values is now again ascending without gaps from number 1.

6.4.3.5 Clear values



The memory batch is emptied. All measurement values are removed. However, the memory remains and is not deleted. If the memory was last active, it remains active and is filled again from the next measurement.

6.4.3.6 Delete



The memory batch is deleted. The batch number (here number 2) can be reused later by creating a new memory batch.

6.4.4 NEW MEMORY BATCH



A new memory batch is created.

It is assigned the lowest free number (1-9) and is empty at the beginning. This new memory batch is activated automatically: the next following measurement is written into this batch.

If the maximum 9 batches have already been created, this menu item is not displayed.

6.4.5 DELETE ALL BATCHES



All memory batches are deleted.
The storage is switched off.

The next memory batch that is newly created is again assigned the number 1.

6.5 SETTINGS



In the settings menu, you can set the language, measuring unit, switch-off time, volume and contrast for your device. These settings are retained even after the device is switched off. These settings are deleted during a factory device reset.

6.5.1 LANGUAGE



English, German, French, Italian, Spanish, Hungarian, Polish and Dutch are available on the device.

6.5.2 UNIT



The unit is set to A/cm by default. If the unit is changed, the new unit will remain in effect even after the instrument is turned off.

You can see which unit is currently active at the bottom right next to the measured value.

You can choose between these units:

A/cm	Amperes per centimeter. The most common unit of measurement for magnetic fields.
kA/m	Kiloamperes per meter. $1 \text{ kA/m} = 10 \text{ A/cm}$
G	Gauss is the unit of magnetic flux density and is proportional to A/cm in air. $1 \text{ G} = \text{about } 0.796 \text{ A/cm}$
Oe	Oersted is the unit of magnetic field strength in the CGS system of units and is equal in magnitude to the unit gauss.
mT	Tesla is the SI unit of magnetic flux density.

Conversion rule for units:

$1 \text{ A/cm} = 0.1 \text{ kA/m} = 1.256 \text{ Gauss} = 1.256 \text{ Oersted} = 0.1256 \text{ mT}$
(or as a rule of thumb: $4 \text{ A/cm} = 5 \text{ Gauss}$)

6.5.3 SWITCH-OFF TIME



Selection of the automatic switch-off time of the device (5 minutes / 10 minutes / 30 minutes / off = the device is always switched on). **Off** should only be selected in special cases, as this can greatly increase the power consumption. The active switch-off time is displayed with an asterisk (*) after the entry.

6.5.4 BEEP VOLUME



Selection of the volume of the signal tone (off / 20% / 40% / 60% / 80% / 100%).
The active beep volume is displayed with an asterisk (*) behind the entry.

6.5.5 CONTRAST



The contrast of the display font can be set on a scale from 0 (low contrast, dark) to 4 (high contrast, bright).
The active contrast is displayed with an asterisk (*) behind the entry.

6.6 SYSTEM



The system menu displays values that are important for information or diagnostics, but cannot be changed. Resetting the device to factory settings is also possible here. The information provided is:

- Revision number of the firmware version. This information could be requested from you by our technicians when searching for an error
- Date and time. The values cannot be changed in the device itself, but they can be changed via the List-Magnetik apps for Windows, Android and iOS.
- Battery voltage: If the value is below 1.2 volt, you should change the battery. If the value falls below approx. 1.15 volts, a warning message is also displayed regularly. Below 1.1 volts, the device will no longer work.
- Factory device reset: the measurement parameters set at the time of factory delivery are restored as they may have been destroyed by an error. The measurement batches and settings are completely deleted. The instrument switches off.
- Serial no: The serial number of your MP-810 is written on the cap of the housing. It was also entered here when the device was set up.
- MAC address: The MAC address is a unique identification of the device and its Bluetooth component. When searching for the device in the **Lima Connect** application, this unique identifier is displayed, so you can distinguish several devices within range.

7 BATTERY REPLACEMENT

As soon as the battery voltage warning („▲ Voltage 1,15V ") appears when the device is switched on, the battery should be replaced.

The device switches off automatically when the battery voltage is less than 1.1 V.

If the display is unclear when the device is switched on, or if an error message **Error-202** is displayed and then the device switches off, the battery is too weak.

Please use only leak-proof batteries.

7.1 USING A RECHARGEABLE BATTERY

If you want to use a rechargeable battery instead of a 1.5V AA battery, do not use a NiMH battery. The output voltage of 1.2V is too low. Voltage fluctuations may even alter the memory in the device.

We have had good experience with rechargeable Li-ion batteries that can be charged via USB cable and have an output power of 1.5V.

8 TECHNICAL DATA

	MP-810A and MP-810T
Measuring units:	A/cm – kA/m – Gauss – Oersted – Tesla switchable (1 A/cm = 0.1 kA/m = 1.256 Gauss = 1.256 Oersted = 0.1256 mT)
Measuring probe MP-810A:	Axial field probe \varnothing 8mm with defined measuring distance of 2.0 mm
Measuring probe MP-810T:	Transversal field probe of 1.7 mm thickness with Hall Sensor distance of 0.9 mm
Measuring range DC:	0-20,000 A/cm
Measuring range AC:	2-20,000 A/cm (50 / 60 Hz)
Accuracy:	in the homogeneous field ± 1 A/cm up to 50 A/cm, ± 2 % of measured value from 50 A/cm
Resolution:	0–200 A/cm: 0.1 A/cm, 200–10,000 A/cm: 1 A/cm, > 10,000 A/cm: 10 A/cm
Frequency range AC:	20 Hz – 100 Hz
Peak Hold:	with impulse duration ≥ 0.25 sec
Display:	OLED Graphic Display illuminated
Menu navigation:	English, German, French, Italian, Spanish, Hungarian, Polish, Dutch
Data logger:	4000 measured values flexibly divisible
Statistics:	count / maximum / minimum / average / standard deviation
Interface:	Bluetooth Low Energy interface for communication with An- droid, iOS and Windows
App for Android, iOS, Windows:	free of charge via Google Play Store, Apple App Store, List- Magnetik website
Power supply:	1x 1.5V AA Mignon
Operating time:	approx. 50 hours
Dimensions:	\varnothing 28 x 140 mm
Weight:	73 g with battery

9 AVAILABLE APPLICATIONS

9.1.1 LIMA CONNECT FOR WINDOWS

On www.list-magnetik.com, in the category **Applications**, you may obtain the free of charge data transfer application **Lima Connect**, to transfer measurement data to your PC.

With **Lima Connect**, you can measure online or read the device's memory, you can evaluate the data statistically or visualize as chart. You can print the results or hand over the data to applications like Microsoft Word and Microsoft Excel.

You can also use it to set the time on your device that will be used during data transfer (Menu „Set Time“)

The screenshot displays the Lima Connect V1.03 software interface. The window title is "Lima Connect V1.03" and the menu bar includes "File", "Language", "KeyEvents", "SetTime", and "Help". The interface is divided into several sections:

- Verbindung** (Connection): Shows a "Disconnect" button and a "Connected" status.
- Probe**: A central image of a probe with "READY" on its display.
- Project data** and **Limits**: Buttons to the right of the probe.
- Read Memory**: A button and a dropdown menu showing "S1 (0)".
- Data**: A table with 4 rows of measurement data.
- List-Magnetik GmbH**: A section on the right with a line graph showing a fluctuating blue line, with "Stat", "+/-", and "<>>" buttons above it.
- Commands**: A section at the bottom right with buttons for "Open Data File", "Save to File", "Print", and "Exit program".
- Copy data to**: A section at the bottom right with buttons for "Clipboard", "MS Word", and "MS Excel".
- Tabelle**: A section next to the data table with buttons for "Delete row", "Delete Tab", and "Sort".

Date Time	No.	value	Unit
22.02.2024 13:34:17	1	244	A/cm DC
22.02.2024 13:34:18	2	148	A/cm DC
22.02.2024 13:34:22	3	130	A/cm DC
22.02.2024 13:34:22	4	154	A/cm DC

9.1.2 LIMA CONNECT APP FOR ANDROID AND IOS

To further process your measurement data, you can pair your TOP-CHECK with mobile Android and iOS devices. This is made possible by Bluetooth Low Energy (BLE) technology. With the **Lima Connect** app you can manage projects and assign the measuring points on a photo. The measurement results can be statistically evaluated and graphically displayed. The app for Android, iOS and Windows is free of charge.

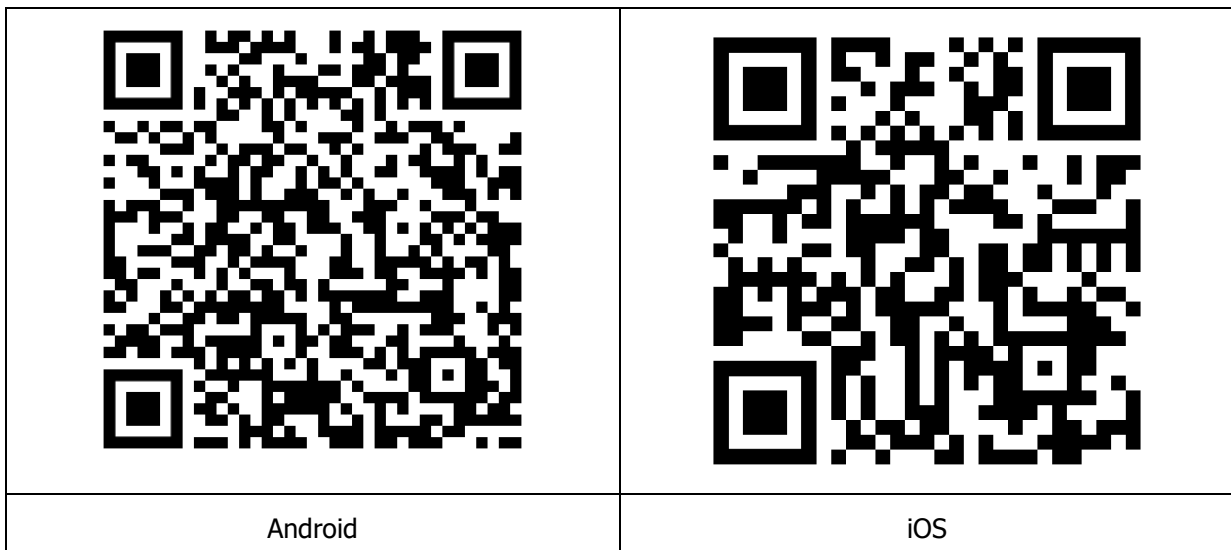

INSTALLING THE BLUETOOTH USB DONGLE



The installation of this software can be necessary for the communication between TOP-CHECK and a Windows PC.

First of all, please try, if the connection between TOP-CHECK and your PC via Bluetooth works without software installation, by plugging in the Bluetooth receiver.

If this does not work immediately, please install the driver software available on <https://www.list-magnetik.com> in the category **Download**.

We supply:

- Coating Thickness Meters
- Magnetic Field Meters
- Devices for Materials Testing
(Permeability and Ferrite content)

We provide expert advice and design metrology solutions tailored to your specific needs.

Fast calibration and repair service



List-Magnetik Dipl.-Ing. Heinrich List GmbH

D-70771 Leinfelden-Echterdingen Max-Lang-Str. 56/2

Fon: + 49 (711) 903631-0 Fax: + 49 (711) 903631-10

Internet: <https://www.list-magnetik.com>

E-mail: info@list-magnetik.de

